

DESIGN NOTES

Ultra-Low Power, High Efficiency DC/DC Converter Operates Outside the Audio Band – Design Note 86

Mitchell Lee

Portable communications products are densely packed with signal processing, microprocessor, radio frequency, and audio circuits. Digital clock noise must be eliminated not only from the audio sections, but also from the antenna which, by the very nature of the product, is located only inches from active circuitry. If a switching regulator is used in the power supply, it becomes another source of noise. The LTC1174 step-down converter is designed specifically to eliminate noise at audio frequencies while maintaining high efficiency at low output currents.

Figure 1 shows an all surface mount solution for a 5V, 120mA output derived from 5 to 7 NiCd or NiMH cells. Small input and output capacitors that are capable of handling the necessary ripple currents help conserve space. In applications where shutdown is desired this feature is available (otherwise short this pin to V_{IN}).

The LTC1174's internal switch, connected between V_{IN} and V_{SW} , is current controlled at a peak of approximately 340mA. Low peak switch current is one of the key features that allows the LTC1174 to minimize system noise compared to other chips which carry significantly higher peak

currents, easing shielding and filtering requirements and decreasing component stresses. Output currents of up to 450mA are possible with this device by connecting the I_{PGM} pin to V_{IN} . This increases the peak current to 600mA, allowing for a high average output current.

To conserve power and maintain high efficiency at light loads, the LTC1174 uses Burst Mode™ operation. Unfortunately, this control scheme can also generate audio frequency noise at both light and heavy loads. In addition to electrical noise, acoustical noise can emanate from capacitors and coils under these conditions. A feed-forward capacitor (C3) shifts the noise spectrum up and out of the audio band, eliminating these problems. C3 also reduces peak-to-peak output ripple to approximately 30mV over the entire load range.

A toroidal surface mount inductor (L1) is chosen for its excellent self-shielding properties. Open magnetic structures such as drum and rod cores are to be avoided since they inject high flux levels into their surroundings. This can become a major source of noise in any converter circuit.

Burst Mode is a trademark of Linear Technology Corporation

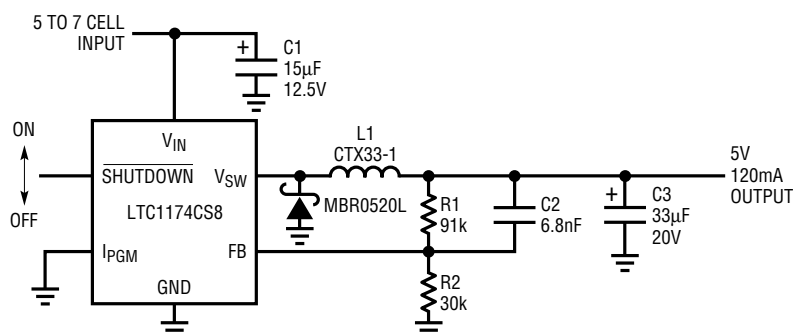

C1: PANASONIC SP SERIES (201) 348-4630
 C3: AVX TAJ SERIES (803) 956-0690
 L1: COILTRONICS OCTAPAK (407) 241-7876

DN86 • F01

Figure 1. Low Noise, High Efficiency Step-Down Regulator for Personal Communications Devices

The interactions of load current, efficiency, and operating frequency are shown in Figure 2. High efficiency is maintained at even low current levels, dropping below 70% at around 800 μ A. No load supply current is less than 200 μ A, dropping to approximately 1 μ A in shutdown. The operating frequency rises above the telephony bandwidth of 3kHz at a load of 1.2mA. Most products draw milliampere range load currents only in standby with the audio circuits squelched, when low frequency noise is not an issue.

The frequency curve depicted in Figure 2 was measured with a spectrum analyzer, not a counter. This ensures that the lowest frequency noise peak is observed rather than a faster switching frequency component. Any tendency to generate subharmonic noise is quickly exposed using this measurement method.

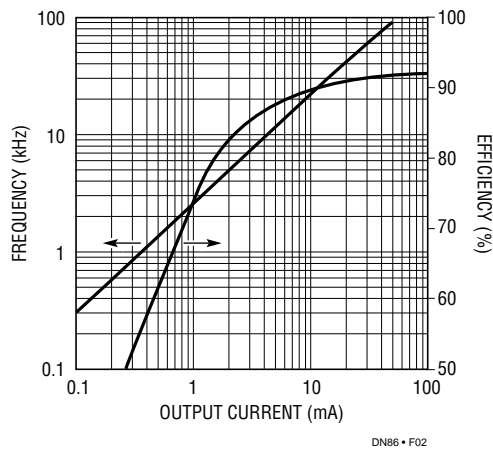

Figure 2. Parameter Interaction

A spectrum analysis of noise from 100kHz to 10MHz is shown in Figure 3. The fundamental switching component in this test was approximately 85kHz, and the second harmonic shows up at twice that frequency. It measures approximately 3mV_{RMS}. Harmonics of the 85kHz funda-

mental disappear into a 10 μ V “mud” between 1MHz and 2MHz. Noise in the critical 455kHz region ranges from 10 μ V to 300 μ V, depending on operating frequency. At 10.7MHz, an important and sensitive intermediate frequency, the noise is broadband and well below 10 μ V_{RMS}.

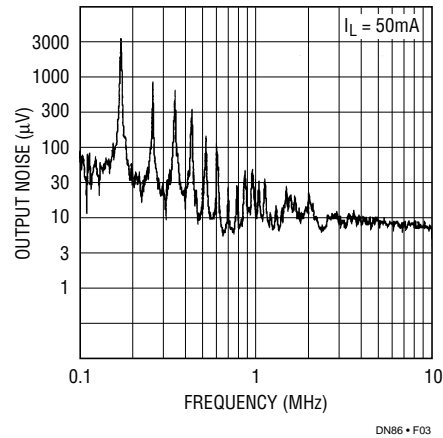
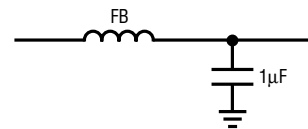

Figure 3. Noise in the 100kHz to 10MHz Band

Further noise reduction is possible by adding an output filter (see Figure 4). A small surface mount ferrite bead is placed in series with the 5V output, close to the LTC1174 and bypassed by a 1 μ F surface mount ceramic capacitor. Noise attenuation at 10MHz exceeds 20dB.



FB: DALE ILB-1206 31 25% (605) 665-9301
1 μ F: AVX 12063G105ZAT (803) 448-9411

Figure 4. An Effective Filter for Attenuating Noise Components Above 1MHz

For literature on our DC/DC Converters, call **1-800-4-LINEAR**. For applications help, call (408) 432-1900, Ext. 361